

Excellence in Manufacturing



Milling-Turning Centers

 **STAMA**

Excellence in manufacturing

STAMA delivers machining centers and milling-turning centers worldwide to manufacturing in almost every branch. As a complete solution for manufacturing at the press of a button. The turnkey business comprises a good 80 percent of all machines delivered – STAMA is one of the top suppliers of individual manufacturing solutions.

Innovative technologies and high-tech machining centers from STAMA point the way ahead. Our best ideas for manufacturing and production.

2



Excellence in manufacturing	2
Save time – cut costs	3
All possibilities, any batch size	4–5
M 7 – complete manufacture from bars	6–7
MT 7 and MT 8 – milling and turning for any batch size	8–13
Automation, handling	14–15
The new generation of MT centers	16–17
Workpiece dimensions	18
Award-winning!	19
Solutions for industry branches	20–23
Spindle construction and tool management	24–25
Service and engineering	26–27

Save time – cut costs

Milling-turning centers from STAMA are highly flexible manufacturing systems. Optimal for complete milling, drilling and turning from bars and chucked parts on all six sides. For evolution or even revolution in manufacturing. For significant time saving, unit cost benefits and innovative power.

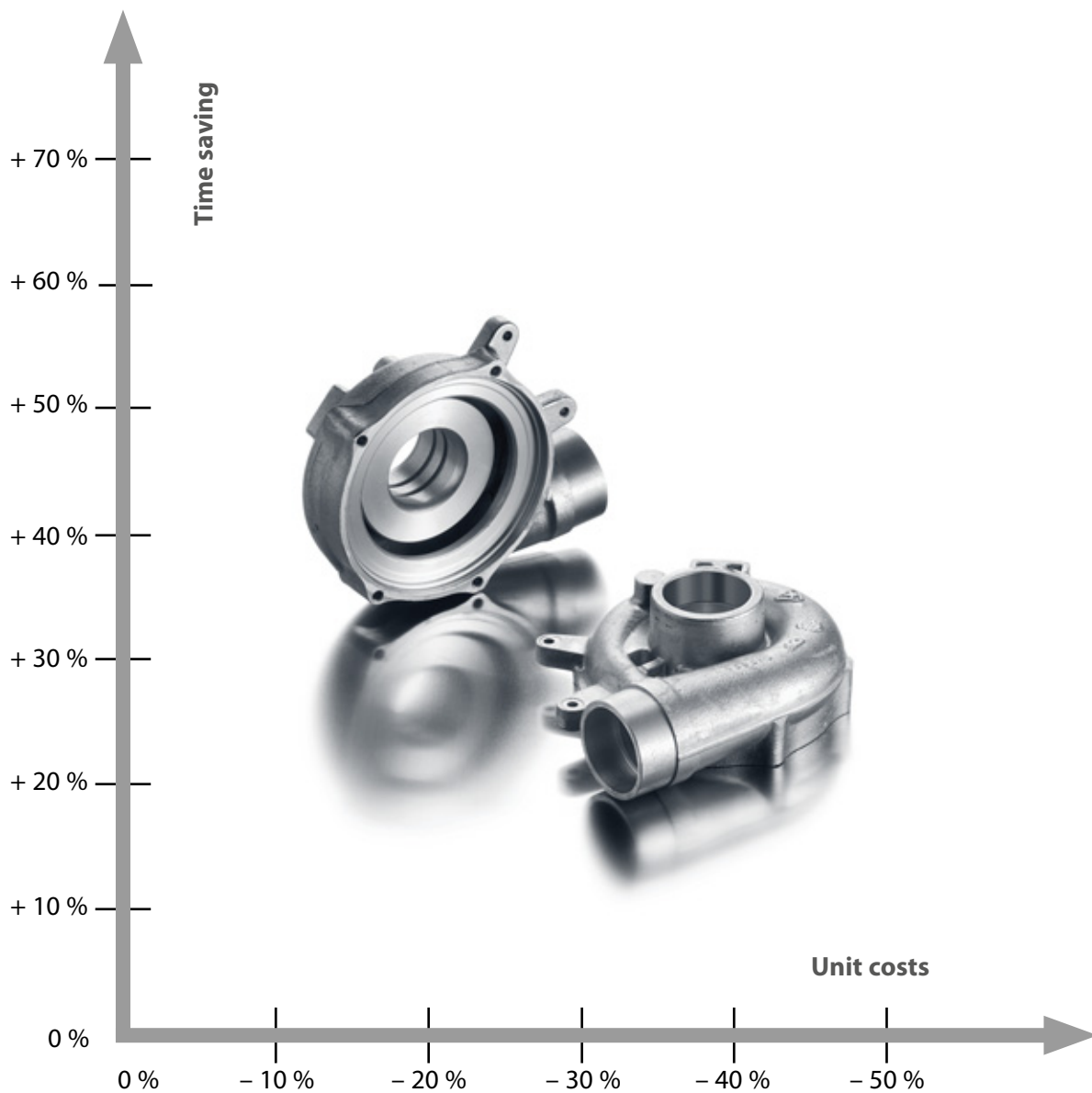

Simple complete manufacture

Machining of all six sides in one work cycle and complete manufacture of the workpiece on just one machining center – STAMA integrated the MT technology in their vertical machining centers in 2000. Completely new manufacturing strategies opened up for the widest range of workpieces.



4

The first users of the MT technology were tool makers and contract manufacturers. Soon after came medical technology, fluid technology, automotive etc. The word quickly spread through all branches that up to 70% time saving and 50% unit cost reduction was realistic. These are clear competitive advantages.

All possibilities, all batch sizes

MT, MT 2C and MT TWIN – leading technologies for demanding application areas in every branch. For single part manufacturing and series production.

Dynamic milling and drilling operations and powerful turning can be combined in any order. Clear and simple logistics for workpiece handling. Ergonomic and clearly laid out work areas shorten and facilitate set-up and changeover. Optimal prerequisites for cost-effective and highly flexible 5-axis complete machining of all six workpiece sides.



5



The idea: complete milling from a bar

The objective: Complete milling and drilling from a bar of all six sides of any workpiece shape on just one machining center in a maximum of two clamping positions. With drastically reduced throughput time from blank to finished part.



6

A manufacturing process that is synchronised over four or five machines according to Taylor's Principles can be implemented on just one M machining center with a good 70% time saving.

Additional benefits: Consistently high workpiece quality, process reliability, availability and unit cost benefits. Fast and flexible reaction to changes in plan. That brings competitive advantage.

M 7 – flexible, fast and 5-axis

Complete machining usually requires 5-axis machining. It must be possible to freely position and swivel workpiece and tools relative to each other. M machining centers swivel the bar freely in the work space with a swivel angle of -30 to 90° . For machining the 6th side, simple standard clampings/jaw chucks and collet chucks are used.

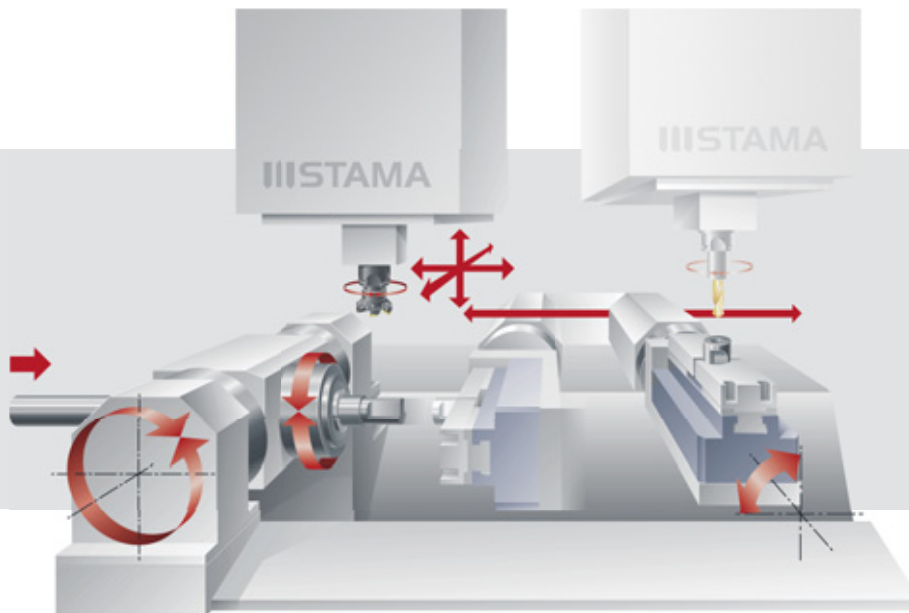

7



Stable machining of longer, slender workpieces

Stable, highly precise 5-axis operations are carried out supported by the automatically swivelling NC tailstock.

M for Milling, T for Turning – MT 7

MT offers in one work space, one milling and one or two turning spindle(s). Complex workpieces and ranges of parts with a large variety of models fit optimally on the compact single place MT centers. For flexible manufacturing following the principle of batch size 1 – set up time 0.

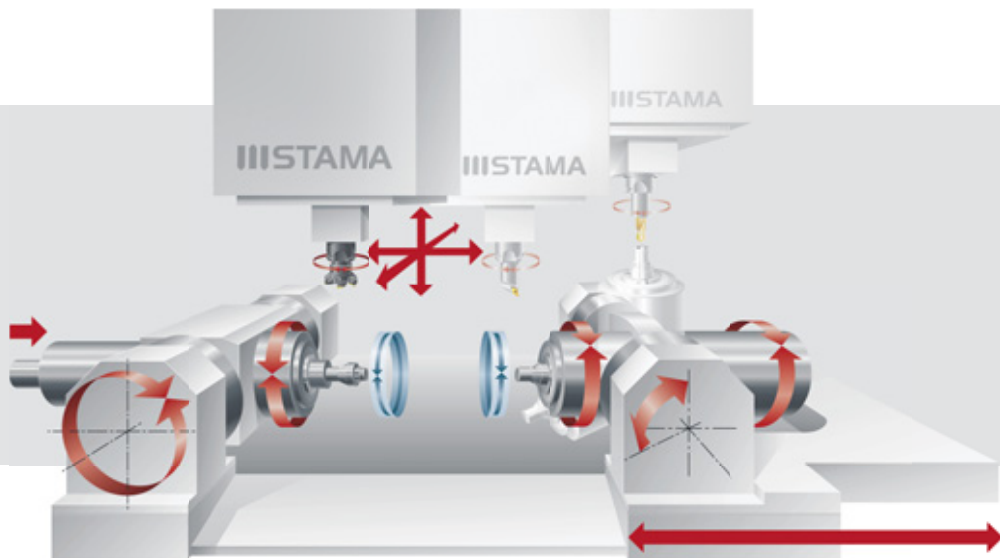

8



Automate flexibly

If the bar diameter changes frequently in a family of parts, and if cut pieces/ shaped parts are machined from the chuck, a re-optimisation after change-over is necessary. The clamping jaws/ collet chucks of the turning spindles are automatically exchanged with a pick-up system and shuttle principle.

Optimal for batch size 1 – set up 0

Small batch sizes, different part families. In day-to-day business batch sizes from 1 to 15 workpieces. Series up to 200 or 500 pieces in the 3rd shift and at weekends. These requirements demand a dynamic center with high changeover flexibility and speed. MT reduces the throughput time drastically and achieves high unit cost benefits.

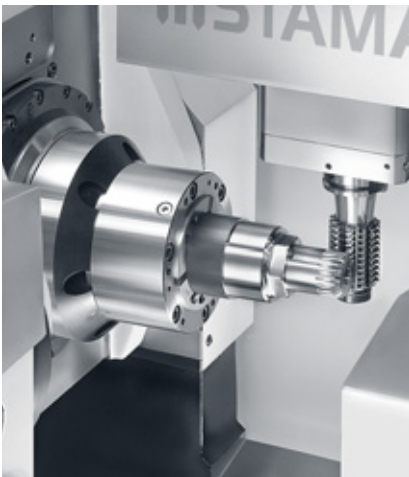

MT 7 2C – two MTs on one bed

Simultaneous complete milling and turning of a workpiece on one machine base with two independent operator platforms (columns). Two place milling-turning centers with MT 2C technology are highly productive manufacturing systems. With almost double the productivity of single place milling-turning centers.

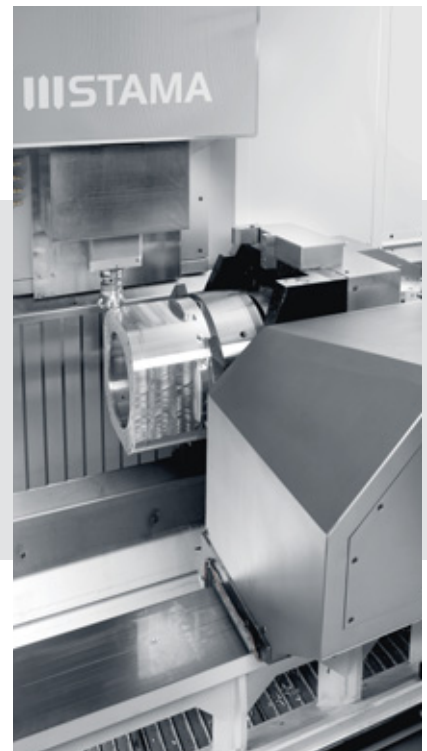

Each work place has one milling and one turning spindle, enabling precise and powerful 5-axis complete machining.

Sides 1–5 are milled and turned in the first workstation, at the same time sides 2–6 of the same workpiece in the second.

Productive and flexible manufacture of any series

The standard clamping, large tool magazine and optimal operator ergonomics ensure high flexibility and short changeover times. The integrated workpiece handling for bars and chucked parts enables reliable, stand-alone 3 shift operation.

Complete manufacture of highly complex workpieces in small series from 10 to 100 and in large series. Productive and flexible.

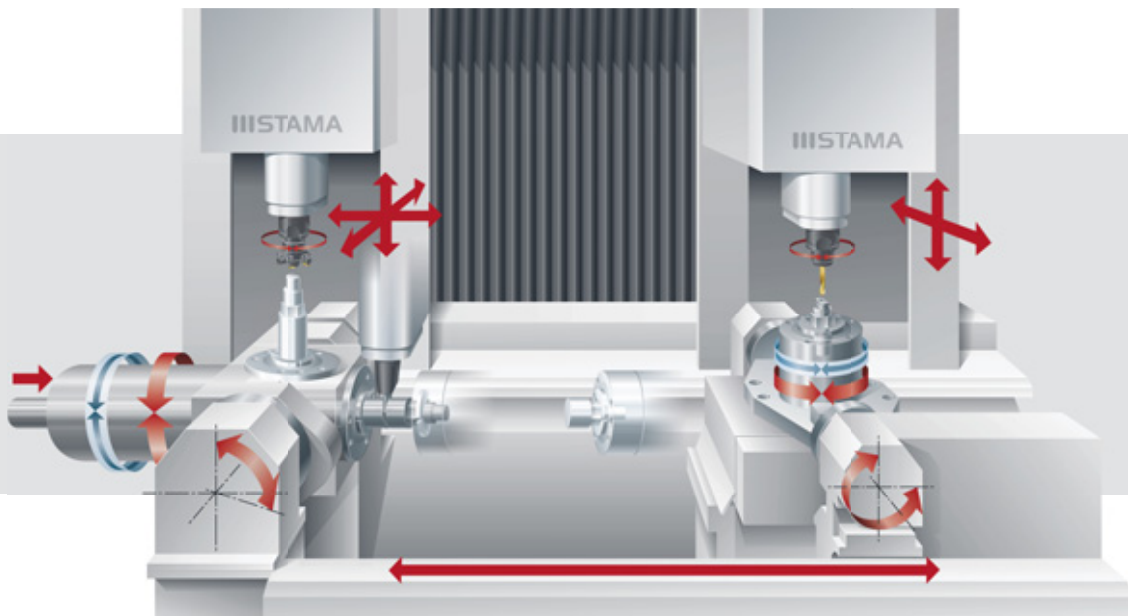

11



In parallel doubly productive

Two work spaces, two operator platforms and constructed according to the PEPS® principle. MT 2C stands for high output on a small footprint.

MT 8 and MT 8 TWIN – stable complete manufacture

MT 8 TWIN unites the basic properties of both technologies: The flexibility and diversity of the MT with the productivity and stability of the TWIN. For the double-spindle vertical milling and turning of blanks, cut pieces and semi-finished products.

MT 8 centers offers total freedom in the individual design of highly productive milling and turning manufacturing processes.

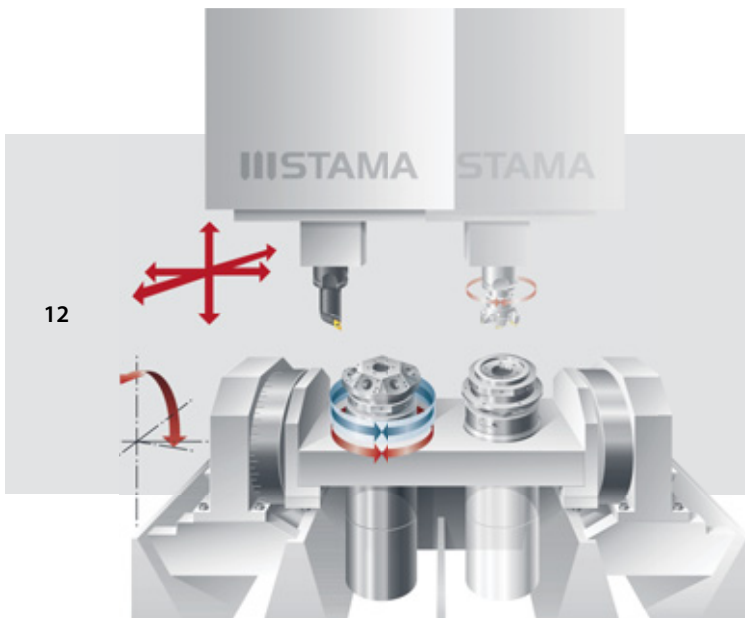

Individual design

One milling spindle and one or two turning spindle(s) in the work space as required. Or two milling spindles and two turning spindles. The swivel axes of the bridge are mounted on both sides. Torque technology developed in-house ensures high positioning accuracy.

For single parts, small and large series

MT 8 TWIN centers are optimally designed for the double-spindle, 5-axis complete machining of large workpieces. Cut pieces, blanks and semi-finished products are aligned with gravity, placed manually or automatically in the clamping chuck of the swivelling turning spindles.



13

Loading, unloading and setting up parallel to main time on two place milling-turning centers reduces non-productive time and ensures more efficient quality assurance, lower logistics expenses and more personal responsibility for the operator.

Teamwork for flexible automation

Automating a manufacturing process is really quite simple. The challenge is to weight flexibility the same as the factors productivity and cost effectiveness.

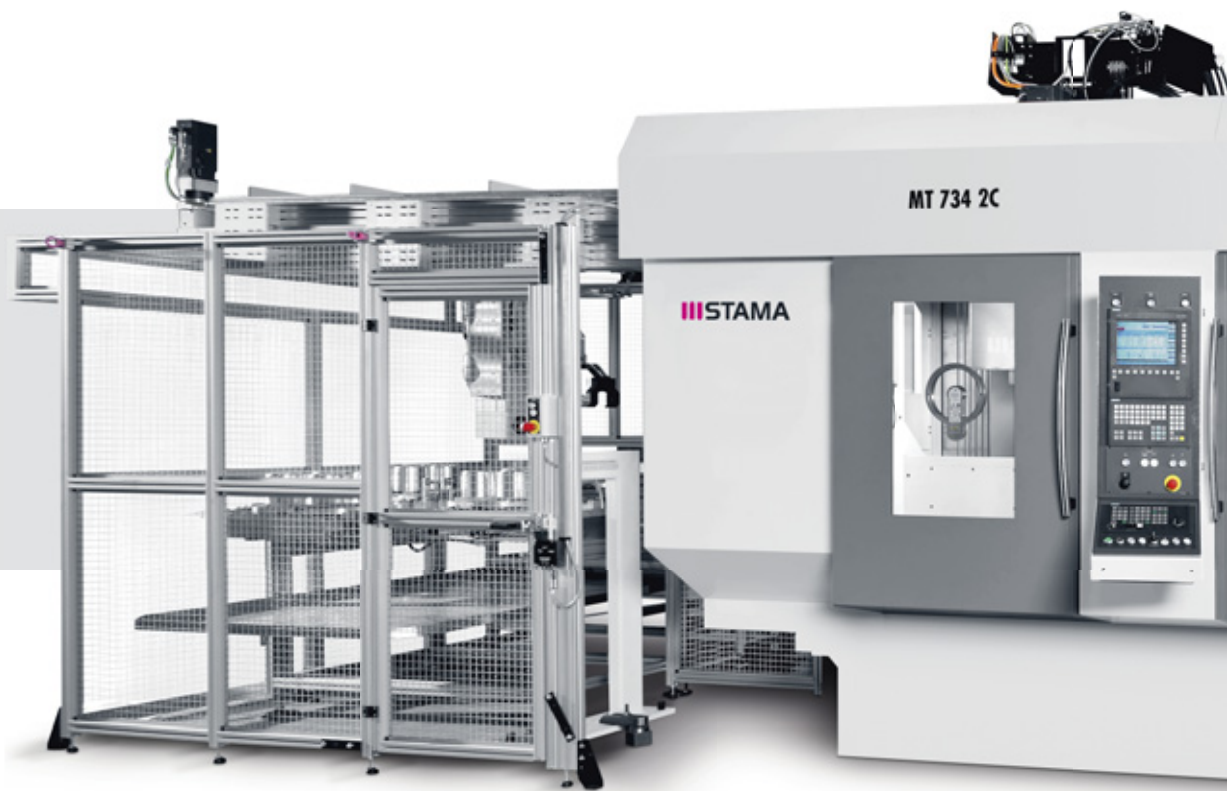

14

The more complex the automated system, the more demanding the controllability of the whole process. Every component of the automated system has to be able to react flexibly to changes, in order not to compromise delivery times, unit price and quality.

Productivity and flexibility in balance

The progress of machining technologies is breathtaking, the competition and the demands for cost-effectiveness, quality and flexibility are constantly increasing. Machine manufacturers and users who cooperate from the start of a project have an advantage with holistic process solutions. Teamwork (also) determines unit costs.



15

MT 734 2C with integrated automated system

The turnkey solution shown here has an integrated automated system with a two-hand gripper. The capacity of the blank and finished part storage, and the large tool magazine enable reliable 3 shift operation.

MT centers – the new generation

STAMA knows its customers individual needs and requirements. A new basic principle for new and future model ranges and types was implemented in 2010 with PEPS® (Performance Efficiency Per Square Meter).



The third generation MT 724 2C with integrated automated system with new design

The constant new and further development of the MT technology and MT centers is also the result of a continuous dialogue with partners, suppliers and – of course – our customers.

Milling-turning power for optimal process solutions

Do requirements like space-saving, energy efficiency and sustainability have as much weight as availability, flexibility and precision? Every branch has its own special focus. What applies to all branches: The workpieces and the manufacturing process are becoming more complex and demanding.



MT 833 TWIN with PEPS® – the second generation with new design

Our key competence is the implementation of the optimal process on standard milling-turning centers. The new MT generation points the way ahead.

The dimensions at a glance

All cutting operations can be combined in any order for an economically and technically optimal machining process: Milling, drilling, tapping, reaming, notching with a rotating cutter, and outer and inner turning, grooving etc. with a stationary cutter – all with high precision and process reliability. Tool delivery is always linear from above.

M 7, MT 7 and MT 7 2C

Bars \varnothing 10 to 102 mm and lengths up to 1000 mm.

All shapes, all materials, max. workpiece length 400 mm.

18

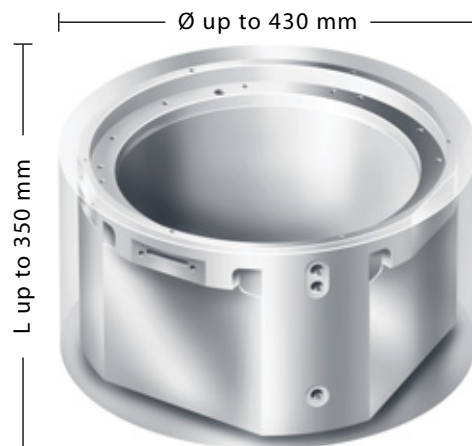
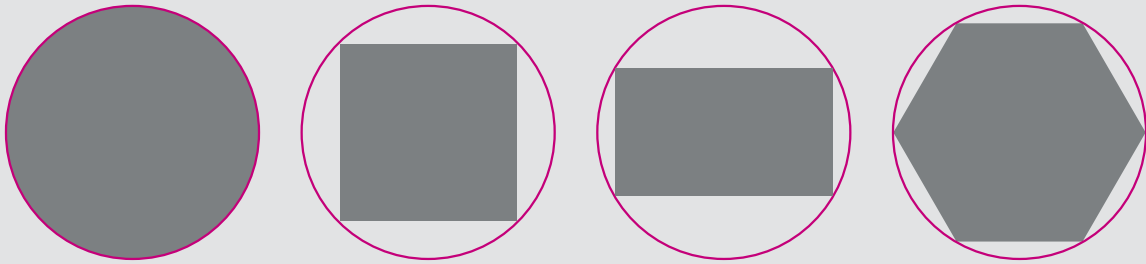

MT 8 and MT 8 TWIN

Cut pieces, semi-finished products, blanks up to \varnothing 430 mm, length up to 350 mm.

Award-winning!

Innovative engineering, convincing machine concepts and a reliable team of qualified employees are our basis for the optimal implementation of customer specific process solutions.

Some projects and concepts have won major awards for their strengths and visions. A challenge and at the same time an incentive for the STAMA company.



19



In all big industry branches

Automotive

A process solution for the automobile industry has to satisfy complex requirements. Carry over parts strategy and model diversity, short product cycles, variable batch sizes, highest quality.



20

Chassis, gear box, motor or brake system components – implementing the optimal manufacturing solution for manufacturer and supplier motivates people and challenges the technology. Innovative, pioneering and unit cost orientated.

STAMA is in action worldwide

Tool industry

Small batch sizes, large series and single part manufacturing. Fast changeover, automated complete manufacture; tool production is a demanding and multifaceted manufacturing field.



21

The process solutions for these diverse ranges of parts have to be flexible, precise and highly productive – for the best cost effectiveness, fast delivery times and technological advances through innovation.

Comprehensive know-how and experience

Medical technology

Instruments, implants and equipment: Requirements known from precision and mechanical engineering are found regularly in medical technology. With this plus of know-how and experience, innovative manufacturing solutions are implemented – components like tank adaptors for anaesthetic equipment, rotors and beakers for laboratory centrifuges, and instrument handles of all types. Complete manufacture with long-term precision and high flexibility.



Fluid technology

Pumps, valves, cylinders, motors, units – anywhere liquids and air are controlled, fluid, hydraulic and pneumatic components are used. The range of parts is as diverse as the application areas: Valves, oil platforms, machine tools, building technology, wind turbines, automotive – in demand are innovative and individual process solutions for small and large workpieces, for small and large series.

for innovative process solutions

Precision engineering

One thinks at once of watches and the proverbial Swiss precision. Precision is of course also found in other areas. Long term precision and a high dynamic belong to the key criteria of a manufacturing solution for the range of precision engineering workpieces. That they are economic and flexible is a basic assumption.



23

Mechanical engineering

The basis for the market and technology leadership of German mechanical engineering is its innovative strength. The machine itself and everything the machine produces – both are developing further rapidly and continually. More stable, more compact, more precise, more flexible, more energy efficient – there are always high demands on high-tech Made in Germany.

In-house precision

Our own spindle engineering assembles per year around 900 milling spindles, turning spindles and torque axis for all STAMA machining centers. Every spindle has a unique number; the spindle's history can be followed over its entire lifetime. Directly driven rotary axis with crash-resistant torque technology guarantees high positioning accuracy and dynamics for the 4th and 5th axis.

24

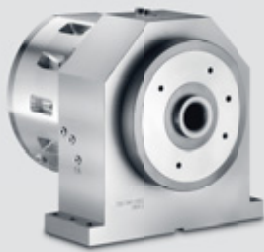

On the left the 4th axis for the round axes of the trunnion table, on the right the 5th axis for mounting on the trunnion table.

All turning spindles are implemented as liquid-cooled motor spindles with synchronous technology. This enables the highest performance. Space-saving and with high thermal stability.



STAMA tool management^{Pat.}

The standard tool magazines are outside the chip and coolant area. The tool change itself is carried out in a pick-up procedure with the headstock.

The consistently short chip-to-chip times with the patented tool changing management help to reduce main times.

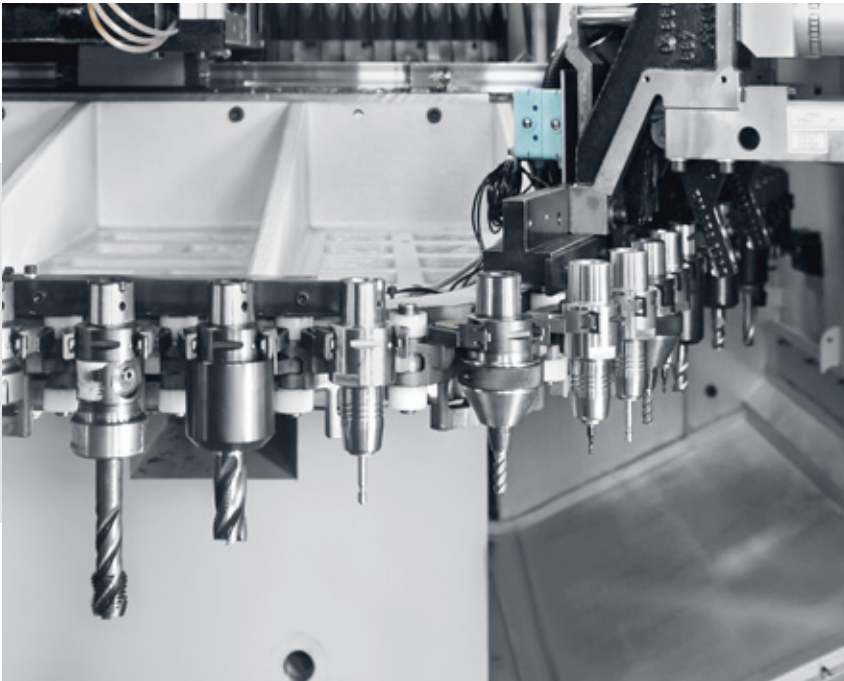

25

As significantly more users are machining with 5-axis, magazines with a large number of tools are included as standard.

For larger tool capacity there is a background magazine with 200 tool places. On a footprint of just 3.5 square metres. The management of complete tool sets parallel to machining time considerably reduces set-up times.

Well looked after worldwide – STAMA service

With standard and turnkey solutions, unexpected problems and disruptions can occur even with planned inspection and maintenance by STAMA technicians and with correct operation of the machining centers by your employees.

To ensure that spare parts and our service technicians are quickly on the spot, we have a network of over 70 service stations.



26

A good 80 percent of machine downtime can be rectified quickly and efficiently with the STAMA Online Service. Whether on-site or by remote diagnosis – together we always find a solution to get your production running again.

You will find the contact information for our service stations worldwide and direct access to the STAMA Online Service SOS on the STAMA website.



Engineering is our key competence

We use our know-how and experience to develop individual turnkey solutions – every branch and every workpiece in special focus. A good 80 percent of all delivered projects are customer-specific process solutions. Of course – there are always different solutions for a manufacturing process. But only one is optimal.



27

STAMA engineering leads and supports all customer projects with teams of experienced designers, engineers, selected partners and suppliers. From project start to customer acceptance, the project management is the central contact for implementing the process solution. All project dates and information flow together here, the project status is always available.

You will find the contact information for our sales engineers and representatives worldwide on the STAMA website.

www.stama.de



STAMA Maschinenfabrik GmbH • Siemensstraße 23 • D-73278 Schlierbach

Phone +49/7021/572-1 • Fax +49/7021/572-229 • info@stama.de

Vertical Machining Centers • Milling-Turning Centers • Turnkey Solutions • Service

 **STAMA**